



IT認證考試題庫 專業平臺

考證寶提供最新考古題與模擬試題
協助您高效通過認證考試

www.kaozhengpro.com

Exam : **HPE2-W09**

Title : Aruba Data Center Network
Specialist Exam

Version : DEMO

1. Switch-1 and Switch-2 are AruDaOS-CX switches, which are part of a Virtual Switching Extension (VSX) fabric. Switch-2 is the primary member. Switch-2 experiences a power failure while Switch-1 remains up. Switch-2's power recovers, and Switch-2 reboots.

Is this one of the things that happens when Switch-2 finishes booting? Solution: Switch-2 waits a period called the link-up delay before it enables Switched Virtual Interfaces (SVIs) on its VSX LAGs.

- A. Yes
- B. No

Answer: A

Explanation:

Switch-2 waits a period called the link-up delay before it enables Switched Virtual Interfaces (SVIs) on its VSX LAGs is a true statement about what happens when Switch-2 experiences a power failure while Switch-1 remains up and then recovers. Switch-1 and Switch-2 are ArubaOS-CX switches, which are part of a Virtual Switching Extension (VSX) fabric. VSX is a feature that provides active-active forwarding and redundancy for ArubaOS-CX switches. The link-up delay timer defines how long a VSX node waits before advertising link state changes to its peer node. This allows the node to synchronize its MAC forwarding, ARP, and routing tables with its peer node before sending or receiving traffic on the newly activated link.

2. Refer to the exhibit.

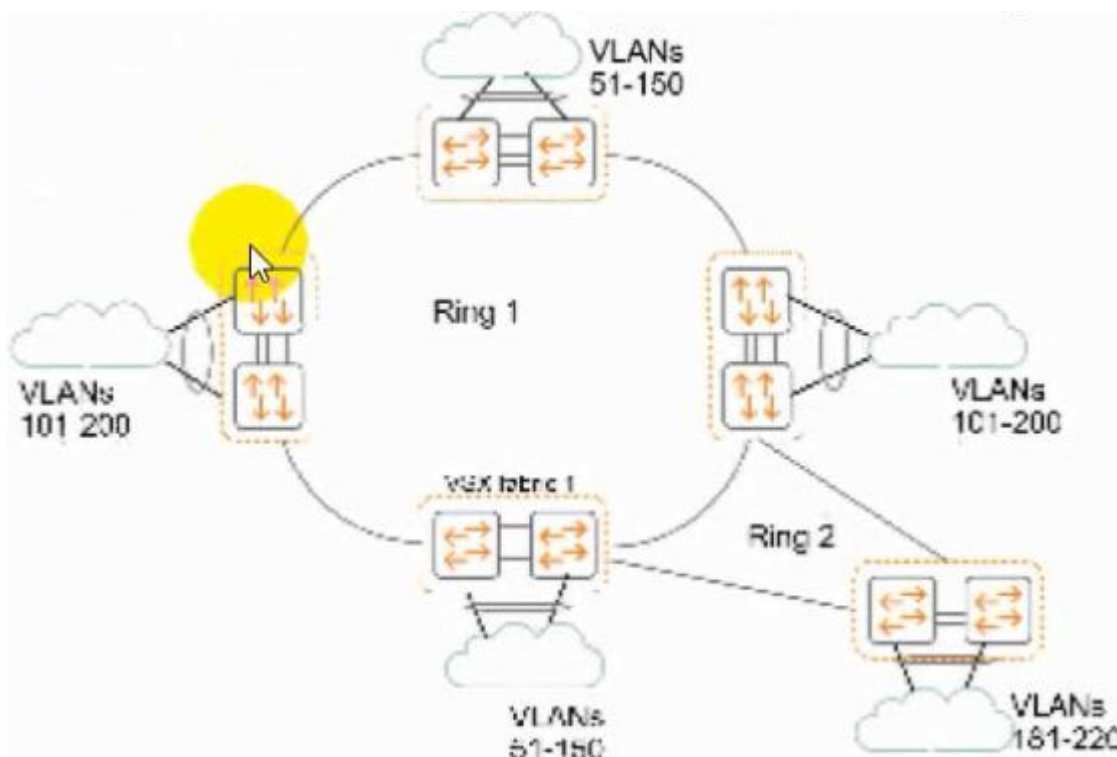

which shows the topology for an Ethernet Ring Protection Switching (ERPS) solution.

Is this a valid design for the control and protected VLANs on the VSX fabric 1 switches?

Solution: Ring 1, Instance 1:

control VLAN: 1000 protected VLANs: 51-135 Ring 1, Instance 2:

control VLAN: 1000 protected VLANs: 136-220 Ring 2, Instance 1: control VLAN:

1001 protected VLANs: 181 -200 Ring 2, Instance 2: control VLAN: 1001 protected

VLANs: 201 -220

- A. Yes
- B. No

Answer: A

Explanation:

Ring 1, instance 1: control VLAN: 1000 protected VLANs: 51-135 Ring 1, Instance2: control VLAN: 1001 protected VLANs: 136-220 Ring 2, Instance 1: control VLAN: 1002 protected VLANs: 181 -200 Ring 2, Instance2: control VLAN: 1003 protected VLANs:201 -220 is a valid design for the control and protected VLANs on the VSX fabric I switches for an Ethernet Ring Protection Switching (ERPS) solution. The control VLANs are unique for each ring instance and do not overlap with any protected VLANs. The protected VLANs are also unique for each ring instance and do not overlap with any control VLANs2.

3. Is this a difference between a typical data center network's requirements and a typical campus network's requirements? Solution: Data center network traffic flows are typically east-west whereas while campus networks experience more north-south traffic.

- A. Yes
- B. No

Answer: A

Explanation:

A data center network is a network that connects servers, storage devices, and other devices within a data center. A campus network is a network that connects buildings and users within a campus area, such as a university or an enterprise. Data center network traffic flows are typically east-west, which means they are between servers or devices within the data center. This is because data center applications often require high-speed communication and data exchange between servers for processing, analysis, or backup. Campus network traffic flows are typically north-south, which means they are between users or devices and external networks, such as the Internet or a wide area network (WAN). This is because campus users often access online services or resources that are hosted outside the campus network12. Therefore, this is a valid difference between a typical data center network's requirements and a typical campus network's requirements.

4. Refer to the exhibits.

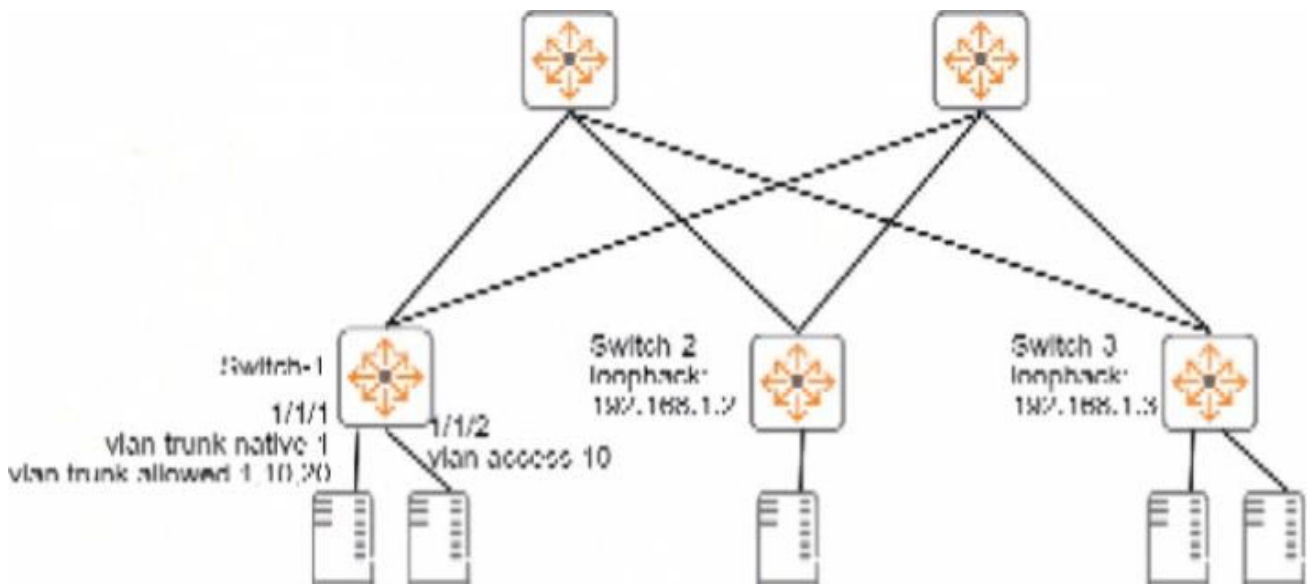

Switch-1# show interface vxlan1 vteps

Source	Destination	Origin	Status	VNI	VLAN
192.168.1.1	192.168.1.2	evpn	Operational	5010	10
192.168.1.1	192.168.1.3	evpn	Operational	5010	10
192.168.1.1	192.168.1.3	evpn	Operational	5020	20

Switch-1# show mac-address-table

MAC age-time : 300 seconds
Number of MAC addresses : 7

MAC Address	VLAN	Type	Port
00:50:56:10:04:25	10	dynamic	1/1/1
00:50:56:11:12:32	10	dynamic	1/1/2
00:50:56:15:16:28	10	evpn	vxlan1 (192.168.1.2)

[output omitted]

Is this how the switch handles the traffic?

Solution: A frame with destination MAC address, 00:50:56:15:16:28, arrives with a VLAN 10 tag on 1/1/1 on Switch-1. Switch-1 encapsulates the frame with VXLAN and an IP header destined to 192.168.1.2.

A. Yes

B. No

Answer: A

Explanation:

A frame with destination MAC address, 00:50:56:15:16:28, arrives with a VLAN 10 tag on 1/1/1 on Switch-1. Switch-1 encapsulates the frame with VXLAN and an IP header destined to 192.168.1.2 is a correct explanation of how the switch handles the traffic. Switch-1, Switch-2, and Switch-3 are ArubaOS-CX switches that use VXLAN and EVPN to provide Layer 2 extension over Layer 3 networks. VXLAN is

a feature that uses UDP encapsulation to tunnel Layer 2 frames over Layer 3 networks using VNIs. EVPN is a feature that uses BGP to advertise MAC and IP addresses of hosts connected to VTEPs. Switch-1 receives a frame with destination MAC address, 00:50:56:15:16:28, which belongs to VM-2 on Switch-3. Switch-1 learns from EVPN that VM-2 is reachable through VTEP 192.168.1.2, which is Switch-3's loopback interface. Switch-1 encapsulates the frame with VXLAN and an IP header destined to 192.168.1.2 and sends it over the underlay network1.

5. Your task is to configure an EVPN solution for a dual-stack IPv4 and IPv6 protocol in the overlay networks. Is this statement about EVPN and IPv6 correct?

Solution: IPv6 protocol can be encapsulated in the underlay network's IPv4 packets.

A. Yes

B. No

Answer: B

Explanation:

IPv6 protocol cannot be encapsulated in the underlay network's IPv4 packets. EVPN is a protocol that provides layer 2 and layer 3 services over an IP network1. It uses VXLAN tunnels to encapsulate Ethernet frames in UDP packets and transport them across the underlay network1. The underlay network can use either IPv4 or IPv6 protocol, but it must match the protocol used by the VXLAN tunnels1. The statement is false because it implies that IPv6 protocol can be encapsulated in IPv4 packets, which is not possible.