



KaozhengPro

IT認證考試題庫 專業平臺

考證寶提供最新考古題與模擬試題
協助您高效通過認證考試

www.kaozhengpro.com

Exam : **UM0-200**

Title : Omg-Certified uml
professional intermediate
exam

Version : DEMO

1. To what does an internal structure of a class refer?
- A. the inheritance structure of that class
 - B. the set of nested classifiers of that class
 - C. the set of structural features of that class
 - D. class and associations owned by that class
 - E. the decomposition of that class in terms of interconnected parts

Answer: E

2. What statements are true about a composite structure? (Choose two)
- A. Collaborations are structured classifiers.
 - B. A structured classifier is also an encapsulated classifier.
 - C. Structured classifiers cannot contain instances of structured classifiers.
 - D. Destroying an instance of a structured classifier normally destroys instances of its parts.
 - E. The behavior of a structured classifier must be completely defined through the collaboration of owned or referenced instances.

Answer: AD

3. An encapsulated classifier is characterized by which fact?
- A. has an encapsulation shell
 - B. can own one or more ports
 - C. hides information from other classifiers
 - D. acts as a package and can own one or more classifiers

Answer: B

4. What interface restrictions does a port have?
- A. multiple required interfaces or multiple provided interfaces
 - B. multiple provided interfaces and multiple required interfaces
 - C. equal numbers of provided interfaces and required interfaces
 - D. exactly one provided interface or exactly one required interface
 - E. exactly one required interface and exactly one provided interface

Answer: B

5. What is an invocation action on a port used for?

- A. sending a message to that port
- B. receiving a message on that port
- C. creating a link and attach it to that port
- D. relaying the invocation via links connected to that port
- E. invoking the behavior of the classifier that owns the port

Answer: D

6. What is NOT a purpose of a port owned by a classifier?

- A. serves as an end point for connectors
- B. specifies an association to the classifier
- C. hides the internals of that classifier from other classifiers
- D. provides a distinct point of interaction between the classifier and its environment

Answer: B

7. Which is true of a provided interface associated with a port?

- A. represents an interface that must be defined within the classifier that owns the port
- B. identifies the services that the object owning the port expects of objects connected via that port
- C. identifies the services that the object owning the port can offer to other objects connected via that port
- D. represents an interface that must be defined in the same package in which the classifier owning the port is defined

Answer: C

8. What does the composite structure notation in the exhibit mean?

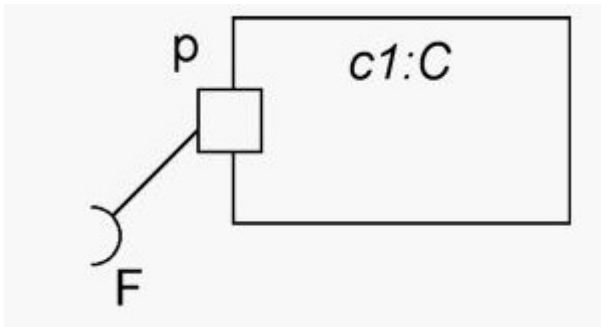

- A. Class C has internal structure.
- B. Object c1 is a kind of component.
- C. Port p is connected to an object called F.
- D. Port p realizes the features defined by interface F.
- E. Port p requires the features defined by interface F.

Answer: E

9. Which list contains only connectable elements?

- A. port and connector end
- B. behavior, port and property
- C. connector end, port and part
- D. property, port, and parameter
- E. behavior, connector end, and port

Answer: D

10. What is NOT true about a roles and role bindings?

- A. A role binding is an association.
- B. The same object may play roles in multiple collaborations.
- C. A role binding maps a connectable element to a role in a collaboration occurrence.
- D. The same connectable element may be bound to multiple roles in a single collaboration occurrence.
- E. A role typed by an interface specifies a set of features required by a participant in a collaboration.

Answer: A

11. What does the composite structure exhibit show?

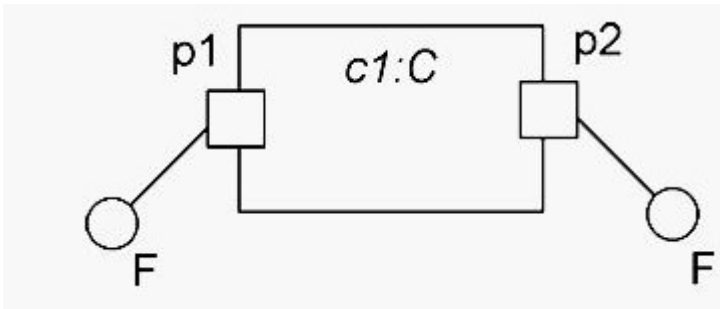

- A. The diagram is not valid.
- B. The two F interfaces must come from different packages.
- C. Requests for behavioral features of interface F through ports p1 and p2 can be distinguished.
- D. Requests for behavioral features of interface F through ports p1 and p2 will always result in the same behavior.

Answer: C

12. Refer to the exhibit. What is the significance of the fact that the Administration interface symbol extends downward rather than leftward?

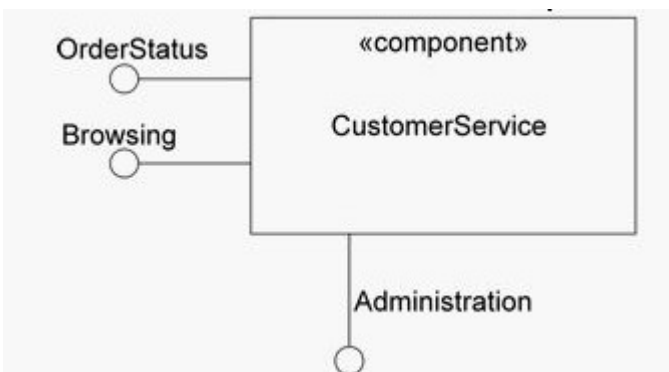

- A. There is no significance.
- B. The interface cannot be provided via a port.
- C. The interface does not require a delegation connector.
- D. The interface is not publicly visible on the component.
- E. The interface is the primary interface for the component.
- F. The interface is the primary provided interface for the component.

Answer: A

13. Refer to the exhibit. How many interfaces does the CustomerService component make visible to its

clients?

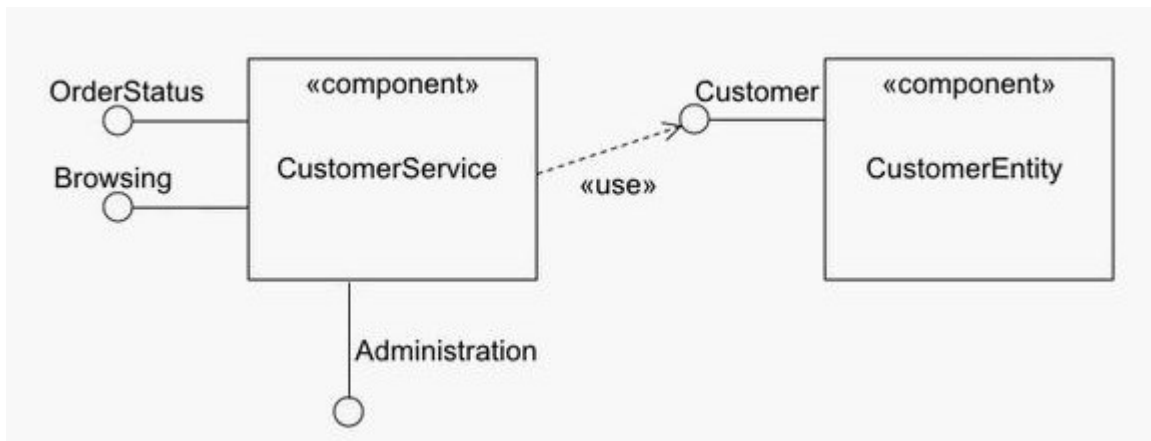

- A. 0
- B. 1
- C. 2
- D. 3
- E. 4

Answer: D

14. What best describes the distinction between a delegation connector and an assembly connector?

- A. A delegation connector can be used to model the internals of a component, while an assembly connector cannot.
- B. Assembly connectors provide white box views of components, while delegation connectors provide black box views.
- C. An assembly connector connects two components while a delegation connector connects the internal contract of a component with its external parts.
- D. An assembly connector connects the required interface or required port of one component with the provided interface or provided port of another component, while a delegation connector connects the external contract of a component with its internal parts.

Answer: D

15. What best describes the semantics modeled by the exhibit?

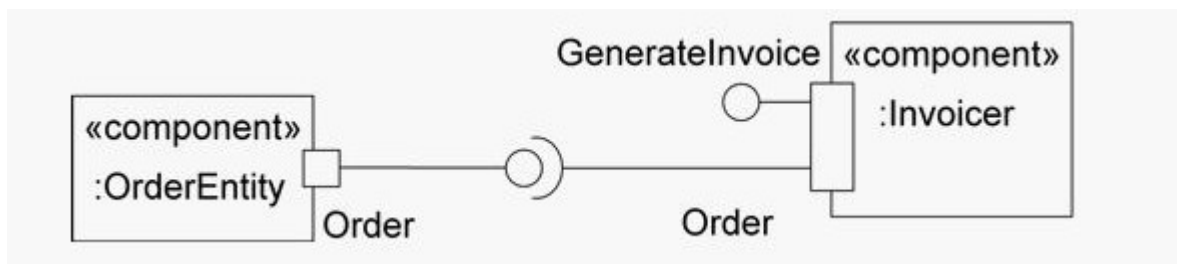

- A. This is an illegal diagram.
- B. The OrderEntity component is part of the internals of the Invoicer component.
- C. The Invoicer has a complex connector that connects the GenerateInvoice interface with the Order interface.
- D. The Invoicer has a complex port that provides the interface GenerateInvoice and requires the interface Order.

Answer: D

16. What most accurately describes the semantics modeled by the exhibit?

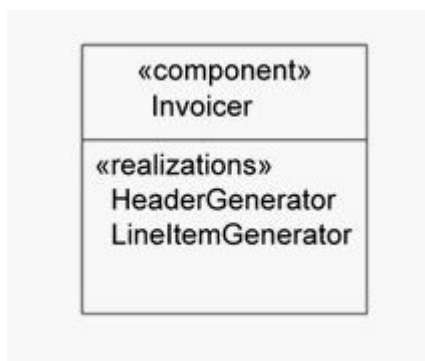

- A. HeaderGenerator and LineltemGenerator realize Invoicer.
- B. Invoicer realizes HeaderGenerator and LineltemGenerator.
- C. HeaderGenerator and LineltemGenerator are Invoicer ports.
- D. An Invoicer component is composed of a HeaderGenerator component and a LineltemGenerator component.

Answer: A

17. How can the internals of a component be presented?

- A. using a complex component connector
- B. component provides port or a component requires port
- C. in a compartment of the component box or a component requires port

D. in a compartment of the component box or via boxes nested within the component box

Answer: D

18. Which must be true in order to use a delegation connector to connect two components?

- A. The components must have complex ports.
- B. One component must be a subtype of the other.
- C. The components must be related to each other via a dependency.
- D. One component must be part of the internal realization of the other component.

Answer: D

19. Assume component A provides an interface P and requires an interface R. In order for a component B to be substituted for component A, what must be true?

- A. Components must be related to each other via a dependency.
- B. The interface that A requires must be type conformant with respect to the interface that B provides.
- C. The interface that B requires must be type conformant with respect to the interface that A provides.
- D. The interface that B requires must be type conformant with respect to the interface that A requires, and the interface that B provides must be type conformant with respect to the interface that A provides.

Answer: D

20. A component may legally participate in which relationship(s)?

- A. dependencies
- B. associations and generalizations
- C. dependencies and generalizations
- D. dependencies, associations, and generalizations

Answer: D